

Our polyester instrument shades provide excellent protection for instrumentation devices such as pressure transmitters, analyzers, pressure switches, controllers, manifolds, etc., and telecommunication and electronic equipments from direct sunlight thereby improving their accuracy and life.

They are easy to install and are ideal for the harsh chemically corrosive and salt laden off-shore or in-land climatic conditions.

The shades are available in various standard dimensions to accommodate single, double and multiple instrument applications.

Basic Characteristics;

- External protection with gel-coat in RAL 7032 colour.
- Self-extinguishing to BS 476:part 7: 1997 class2
- Resistant to UV rays
- Non Corrosive accessories & hardware
- Anti static
- SS 304 pipe mounting clamps
- SS 304 back plate
- High tensile & impact strength

Standard Ranges

[Dimensions in millimetres]

Dimensions			Item Code	No. of Mounting Clamps	Back Plate Size
Width W	Height H	Depth D			L x B
350	350	450	IS-3535/45	2	200 x 200
430	500	500	IS-4350/50	2	250 x 250
500	430	570	IS-5043/57	2	250 x 250
520	430	620	IS-5243/62	2	250 x 2000

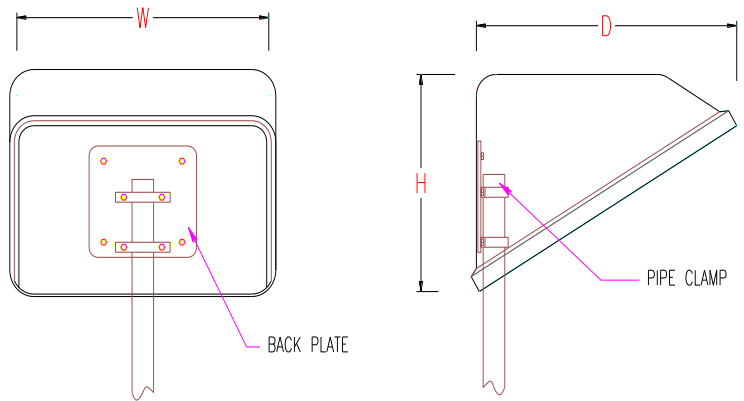

Standard Ranges

[Dimensions in millimetres]

Dimensions			Item Code	No. of Mounting Clamps	Back Plate Size
Width W₁	Height H₁	Depth D₁			L x B (2nos.)
600	500	500	DIS-6050/50	4	200 x 220
760	500	500	DIS-7650/50	4	220 x 220
830	430	650	DIS-8343/65	4	200 x 220

